



# Technical Data Sheet

## PB-EXT-30 - Extender 30 mm PB pedestal

### COMPOSITION

PB-EXT-30 is made of one piece.

### CHARACTERISTICS

Weight: **0.150 kg**  
 Height: **30 mm**  
 Diameter: **ø 199 mm**

### MATERIAL

Copolymer polypropylene (CPP)  
 Composition: +/- **80%** first grade pre-selected recycled PPC, and +/- **20%** Talc + Masterbatch black  
 Designed and manufactured in Europe.  
 Use of recycled materials exclusively of EU origin.  
 Resistant to weathering, sea salts, algae and a wide range of chemicals.  
 Temperature range: **-30 °C to +80 °C**.

### PACKAGING

Pieces per box: **48 pcs**  
 Box weight: **8.60 kg**  
 Pieces per pallet: **1920 pcs**  
 Pallet dimensions: **100 x 120 x 220 cm**

### APPLICATIONS

The extender (**PB-EXT-30**) is a 30 mm extension that is placed under the pedestal and allows to increase the height of a pedestal by 30 mm. It is possible to stack up to 4 elements and reach an additional height of 120 mm.

- Reduces work stoppages.
- Simply clips under the pedestal, without tools.
- Compatible with all **PB** (except for PB-00) and **PB-S** pedestals and with the slope corrector.

### SAFETY INSTRUCTIONS

Buzon pedestals and accessories are designed to support external raised floors for pedestrian traffic only and are not designed to support or be subjected to moving and/or vibrating machinery & equipment, including maintenance, cleaning vehicles, automobiles and other similar equipment.

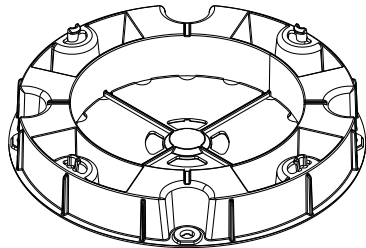
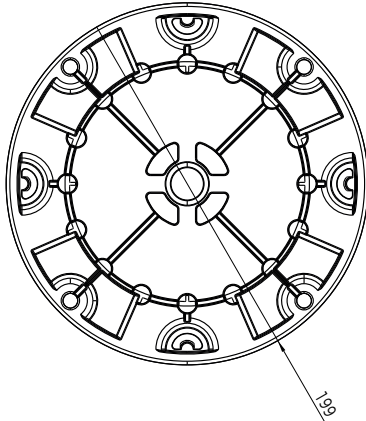
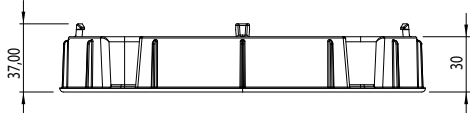

Buzon has a policy of continuous improvement and reserves the right to modify, revise or change the above specifications without notice. This brochure is for descriptive purpose only and is based on the product as on the date of publication of this information.

